

SFIXL Technical form & Price list

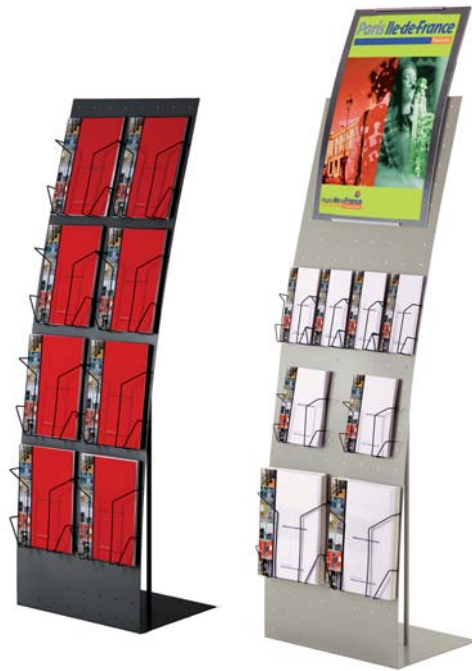

Description

Perforated double width curved display unit with or without adjustable trays.

Brand : Signarco®
 Designer : Stéphane Geslin
 Made in France

Individually boxed
 Double-flap resilience
 « Douflin » and anti-deformation
 protective foam

i with ballast or fixed on floor
 (see accessories)

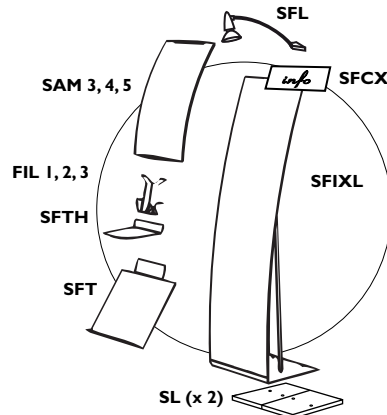

i Colours to order and customisation for orders over 50

Materials : 2 mm steel Finishings: High-resistance industrial epoxy paint				SFIXL SIGNARCO® Range	
Standard colours grey 9006 (alu)				Weight	Contents
Matt black					
	SFIXL	Double perforated display unit (480 x 1500 mm)		18 kg	
		Accessories			wire tray max. on SFIXL
	FIL1	Wire tray for A4 size document (width 230 mm ; depth 35 mm)		0,08 kg	8
	FIL2	Wire tray for A5 size document (width 154 mm ; depth 35 mm)		0,062 kg	10
	FIL3	Wire tray for 1/3 A4 size document (width 108 mm ; depth 35 mm)		0,054 kg	20
	SAM4	Poster frame A4 (21 x 29,7 mm) (Vertical ou Horizontal)		0,8 kg	
	SAM3	Poster frame A3 (29,7 x 42 mm) (Vertical ou Horizontal)		0,8 kg	
	SAM5	Poster frame 40 x 60 (400 x 600 mm) (Vertical)		2,2 kg	
	SAM2	Poster frame 60 x 80 (640 x 835 mm) (Vertical)		4,4 kg	
	SL	Ballast to screw (240 x 350 mm) 2 units required		6,2 kg	
	SFL	Low-wattage lighting (20w)		0,4 kg	
	SFTH	Horizontal shelf (200 x 240 mm)		0,9 kg	2
	SFT	Book support (350 x 460 mm)		2,3 kg	
	Option	Ring bindings \varnothing 15 mm entraxe de fixation 265 mm		0,04 kg	
	SFCX	Clip for titling on SFIXL (hauteur 120 x 480 mm)		0,45 kg	